



SPECIFICATION

1. DESCRIPTION

The DK106 is specially design for low power switch mode control, it is widely use in small household electrical appliances.

2. APPLICATIONS

- Battery charger
- Power AC/DC adapters
- STB power supply
- Electromagnetic oven power supply
- DVD/VCD power supply
- Air conditioner power supply
- AC/DC LED driver applications
- TV/Monitor power supply

3. MAIN FEATURES

- 85V—265V wide range AC power input.
- Double chip design with Bipolar Junction Transistor (BJT) to save cost.
- Large scale MOS digital circuit design with E class BJT driving, so that to enhance its High Voltage Resistance capability.
- Self-power supply circuit design, no need to additional IC to supply for electricity as to reduce component and cost
- Internal integrated constant high voltage current driving circuit, no need for additional resistance.
- Over current, Over loading, Over temperature, Over voltage, Output short circuit and photo-coupler Failure Protection.
- Internal Ramp Compensation circuit to keep the stability of the circuit in low voltage and high power condition.
- Internal PMW oscillation circuit with Frequency jittering control to keep EMC characteristics.
- Internal Frequency Conversion. Frequency-down in low load condition, comply with the Europe Standard (stand power<0.3W), also reduce the output voltage ripple.
- Ramp current drive circuit included to reduce IC power loss and raise circuit efficiency.
- 4KV Anti-Static ESD test.

4. POWER RANGE

Input Voltage	85-264V AC	85-145V AC	180-264V AC
MAX. output power	6W	8W	8W

5. CONNECTION DIAGRAM

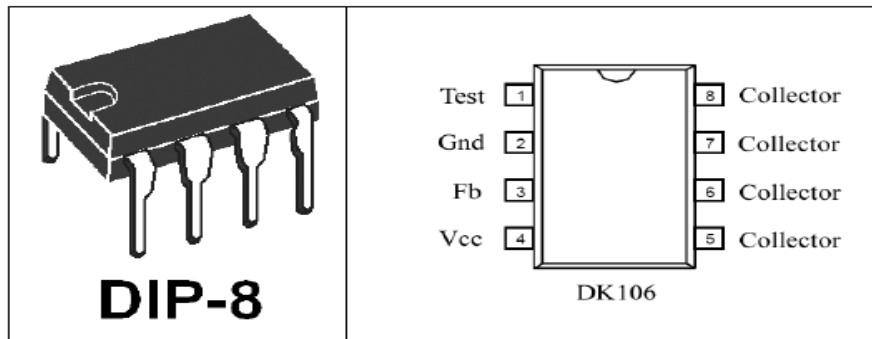

PIN FUNCTION

Pin NO.	Pin Name	Function
1	Test	Testing pin, suggested to be unloaded.(Prohibited to be connected to other circuits)
2	GND	Ground reference
3	Fb	Feedback control pin
4	Vcc	Power supply of the control circuits
5,6,7,8	Collector	Output pin. Connected with internal high voltage Collector point and switch mode transformer.

6. BLOCK DIAGRAM

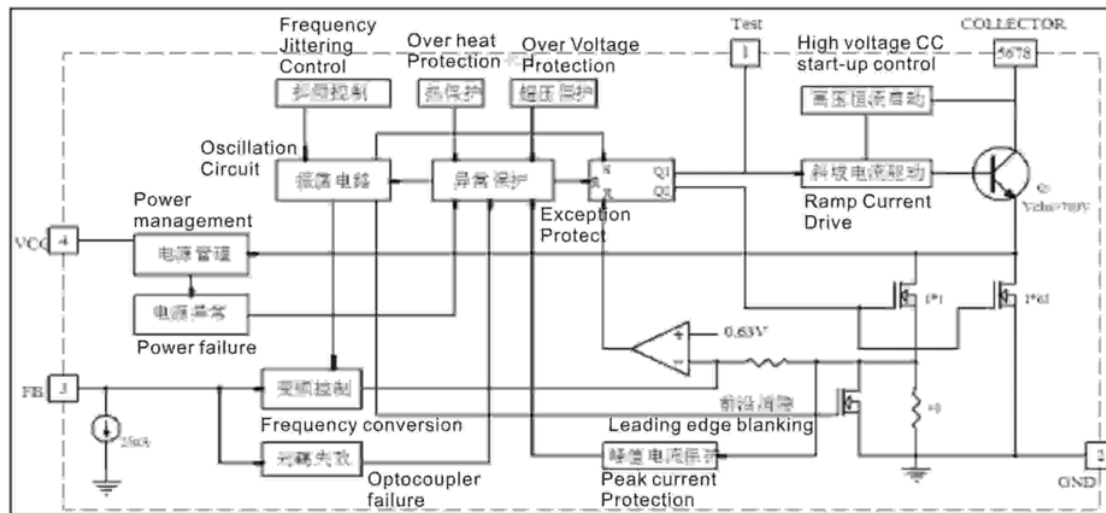

7. ABSOLUTE MAXIMUM RATINGS

Symbol	Parameter	Value	Unit
Vcc	Supply voltage	-0.3V--9	V
Ivcc	Current of supply voltage	40	mA

Vpin	Pin voltage	-0.3--Vcc+0.3	V
Vcol	Collector to GND voltage	-0.3--780	V
Ip	Peak current	400	mA
Pd	Dissipation power	1000	mW
Tc	Case operating temperature	0--125	°C
Tstg	Storage temperature	-55--150	°C
Tsol	Soldering temperature	+280	°C/5S

8. ELECTRICAL CHARACTERISTIC

Parameter	Condition	Value			Unit
		Min.	Typ.	Max.	
Vcc (Work Power Supply)	AC input: 85V-265V	4	5	6	V
Start threshold Voltage	AC input: 85V-265V	4.8	5	5.2	V
Stop threshold Voltage	AC input: 85V-265V	3.6	4	4.2	V
Current of Vcc	Vcc=5V, Fb=2.2V	10	20	30	mA
Start time	AC input: 85V	--	--	500	mS
Collector Protection Voltage	L=1.2mH	460	480	500	V
BJT Breakdown voltage	Ioc=1mA	700	--	--	V
Switch tube Current	Vcc=5V, Fb=1.6V---3.6V	320	360	400	mA
Peak Current Protection	Vcc=5V, Fb=1.6V---3.6V	380	400	420	mA
Oscillation Frequency	Vcc=5V, Fb=1.6V---3.6V	60	65	70	KHz
Changing PWN switch Frequency	Vcc=4.6V, Fb=2.8V---3.6V	0.5	--	65	KHz
Step of jittering frequency	Vcc=4.6V, Fb=1.6V---3.6V	0.8	1	1.2	KHz
Temperature protection	Vcc=4.6V, Fb=1.6V---3.6V	120	125	130	°C
Duty cycle of PWM	Vcc=4.6V, Fb=1.6V---3.6V	5	--	70	%
Fb control voltage	AC input: 85V-265V	1.5	--	3.6	V

9. OPERATION PRINCIPLE

9.1 Start Up

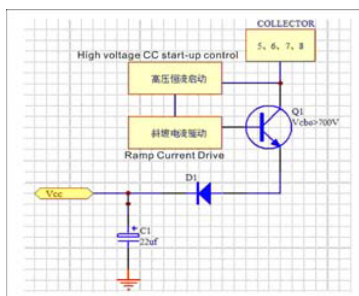

Start up principle diagram

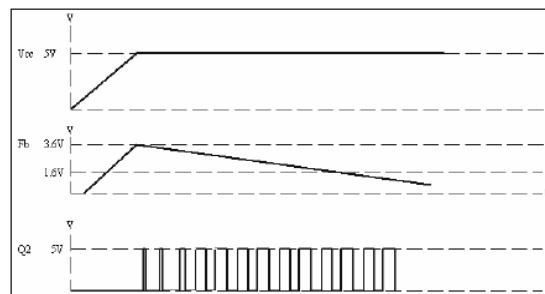

Start up sequence diagram

9.2 Normal Working Sequence Diagram

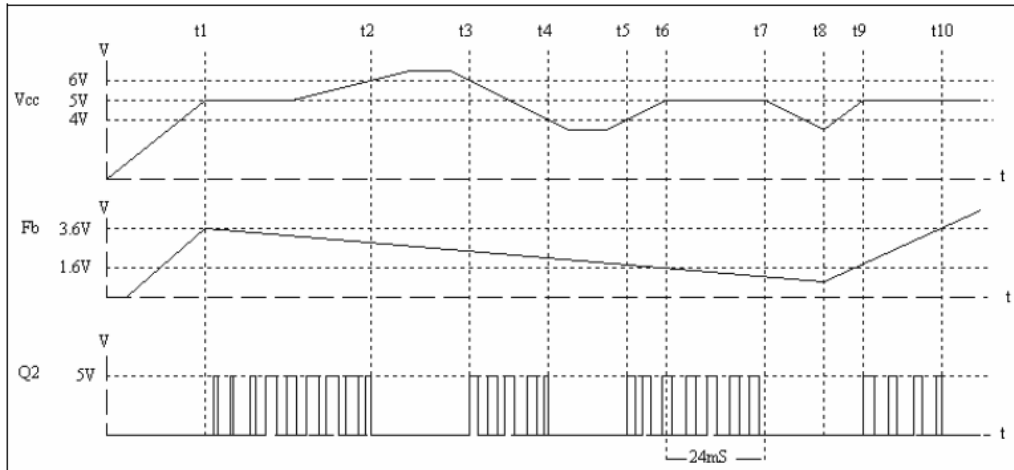

9.3 Control Pin---Fb

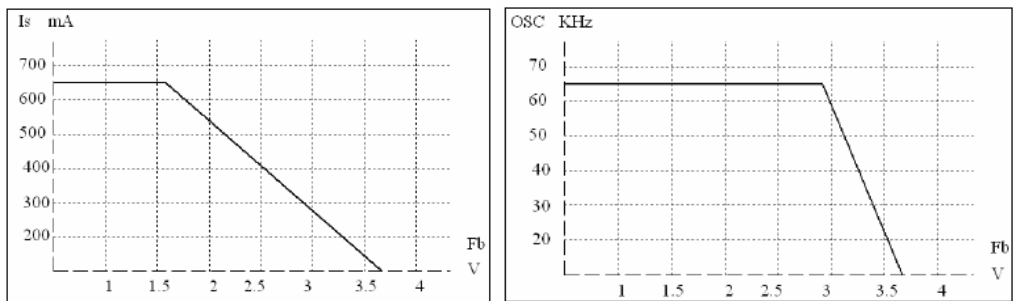

Is & Fb sequence diagram

Fb & working frequency (PWM) sequence diagram

9.4 Self-Power Supply Circuit (National patent owned)

There is self-power supply circuit inside the IC, which can control the power voltage about 5V for the electricity consumption of the IC itself. It can only afford the electricity consumption of itself only but can not afford for the external circuit.

9.5 Leading Edge Blanking (LEB)

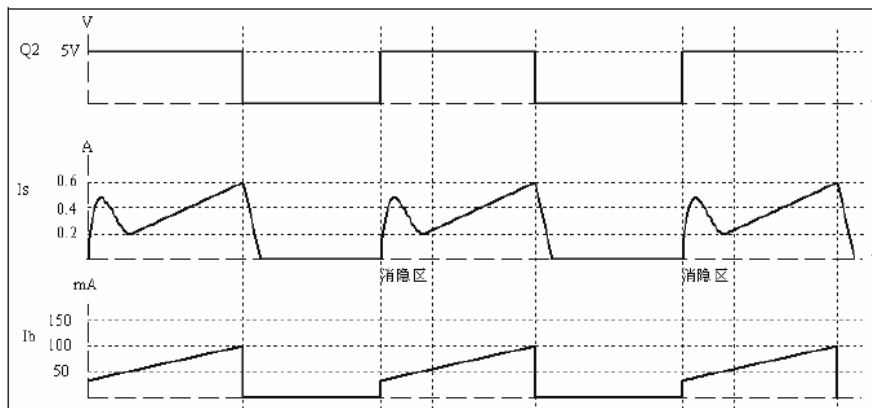

Ib & Is sequence diagram

9.6 Frequency Jittering Circuit

By sweeping the switching frequency around its nominal value 65KHz, it spreads the energy content on adjacent frequencies rather than keeping it centered in one single ray. This offers the benefit to artificially reduce the measurement noise on a standard EMI/EMC receiver and pass the tests more easily.

9.7 Over Temperature Protection (OTP)

When the controller detects the device temperature exceeds 125°C, OTP is activated. It stops the switching operation immediately and enters into the stop status. The controller will restart to switching operation when the temperature falls to 120°C.

9.8 Over Current Protection (OCP)

Whenever the collector current (I_p) abnormally exceeds the maximum current limit of 400mA, the controller would stop operation and enters into stop status.

9.9 Abnormal Voltage Protection

Whenever the power voltage (V_{cc}) abnormally exceeds 6V and drops under 4V, the controller would stop operation and enters into stop status.

9.10 Over Collector Voltage Protection

Whenever the voltage of the collector pin exceeds the limit, the controller will decrease the power output to make sure the collector pin coming back to normal. It could reduce the stress of the power transistor and the protect power transistor from avalanche damage.

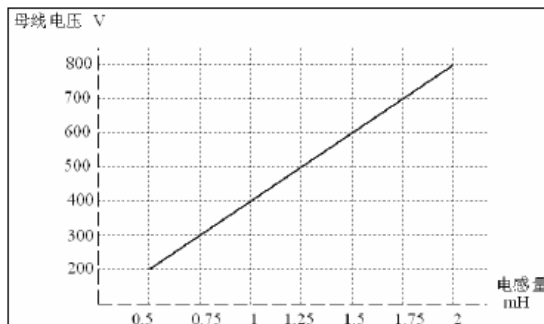
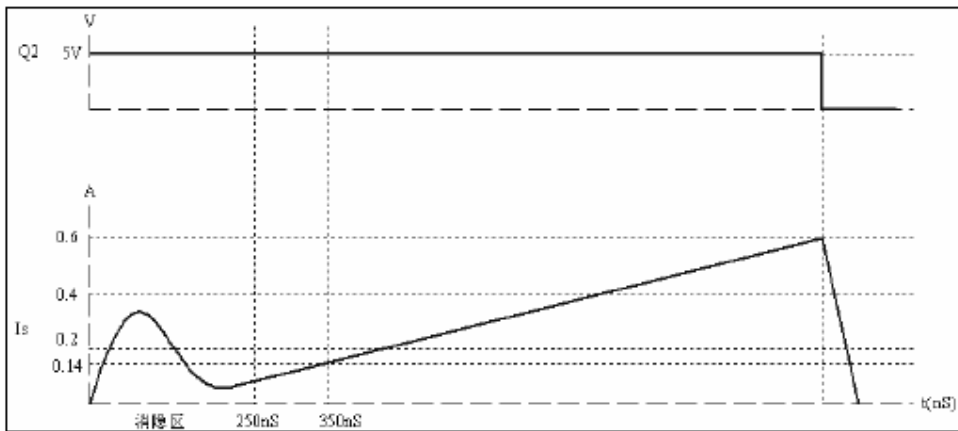

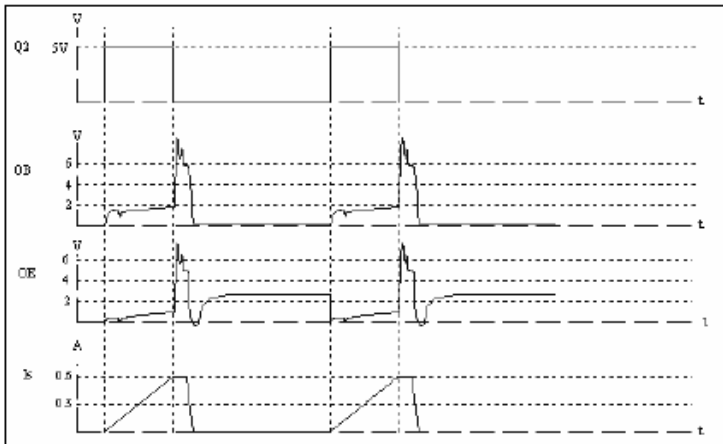

10. IC TESTING

10.1 High Voltage Resistance Test

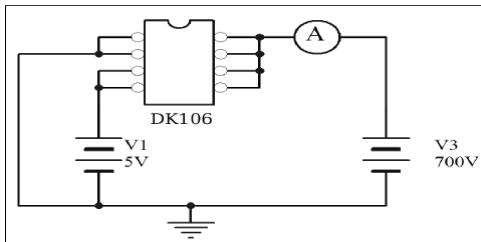

10.2 Electrical Test

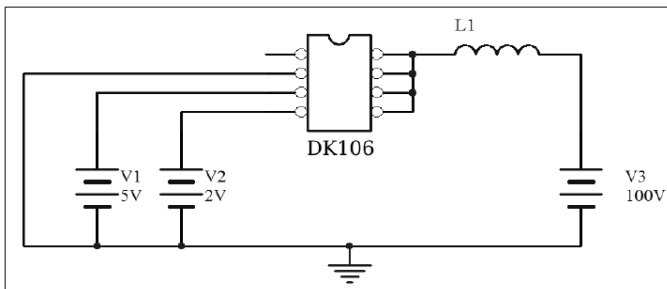

11. TYPICAL APPLICATION SAMPLE

(12V0.5A OUTPUT OFF-LINE FLYBACK TYPE SWITCHING POWER SUPPLY)

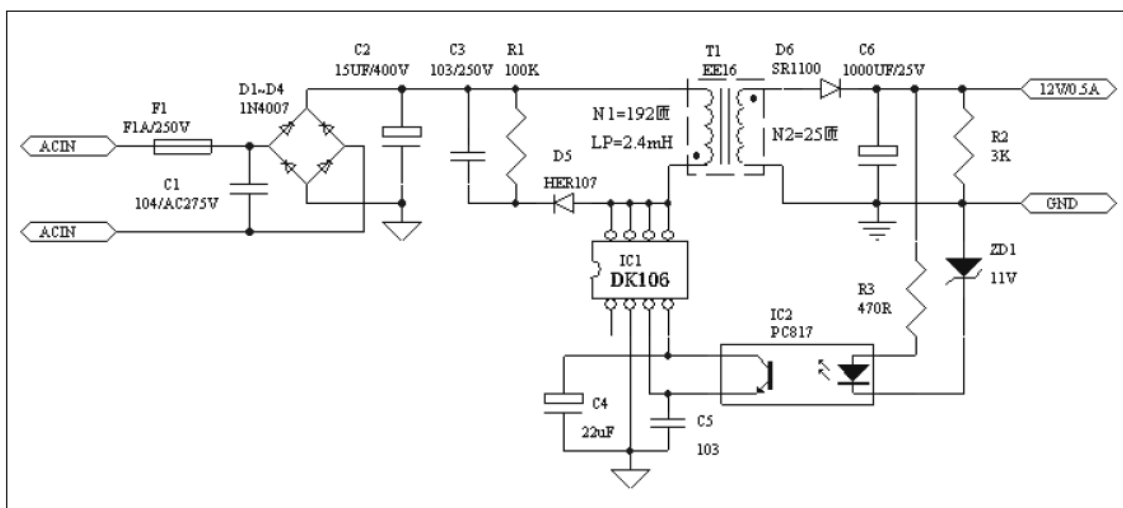

11.1 Components list

NO.	NAME	SPEC. / MODEL NO.	POSITION	USED QTY	REMARK
1	Fuse	F1A/AC250V	F1	1	
2	X capacitor	104/AC275V	C1	1	
3	Diode	IN4007	D1~D4	4	
4	Diode	HER107	D5	1	
5	Diode	SR1100	D6	1	
6	Zener Diode	11V/0.5W	ZD1	1	
7	Electrolytic capacitor	15UF/400V	C2	1	
8	Electrolytic capacitor	22UF/16V	C4	1	
9	Electrolytic capacitor	1000UF/25V	C6	1	
10	Ceramic capacitor	103/250V	C3	1	
11	Ceramic capacitor	103/25V	C5	1	
12	IC	DK106	IC1	1	
13	IC	PC817	IC2	1	
14	Resistance	100K/0.25W	R1	1	
15	Resistance	3K/0.25W	R2	1	
16	Resistance	470R/0.25W	R3	1	
17	Transformer	EE16	T1	1	

11.2 TRANSFORMER DESIGN (For reference only)

11.2.1 Parameter confirmation: confirm the below parameter before transformer design

- (1) Input voltage range (for example :AC85V-265V)
- (2) Output Voltage and current (for example DC12V 0.5A)
- (3) Switching frequency (for example F=65KHz)
- (4) MAX. duty cycle (for example D=0.5)

11.2.2 Core selecting

- (1) Input power calculation

$P = P_{out} / \eta$ (η is the efficiency of the power supply, take it 0.8 for example),

$P_{out} = V_{out} * I_{out} = 12V * 0.5A = 6W$, $P = 6 / 0.8 = 7.5W$.

(2) Choose the core:

Checking via supplier or the correlative chart can know that EE16 or EE19 core is suitable for 15W power supply. Now we choose EE16 for below calculation.

11.2.3 Input voltage setting

Input voltage is AC85V-265V, as to get the MAX. power value according to the lowest voltage and take the voltage loss(from wires and rectification) into consideration, $V_s=80*1.3=100V$.

11.2.4 Conduction time $T_{on}=1/F*D=1/65*0.5=7.7\mu S$

11.2.5 Number of the original(input) turns (N_p)

$$N_p = (100 * 7.7) / (0.2 * 20) \approx 192$$

PS: ΔB_{ac} ---Alternating working magnetic flux density (mT), set to be 0.2

A_e -----Core effective area (m²), EE16's A_e is 20 m²

11.2.6 Number of the output turns (N_s)

$$N_s = (13 * 192) / 100 = 25$$

PS: V_{out} ---Output voltage= $12V+1V=13V$, take the voltage loss (from wires and rectification) into consideration.

V_{or} -----Flyback voltage= $100V$, set it lower then 150W for the safety of IC.

11.2.7 Input inductance value (L_p)

$$L_p = (100 * 7.7) / 320 \approx 2.4 \text{ (mH)}$$

PS: I_p ---Input peak current (it is set to be 320mA in the IC)

11.2.8 Verification of the design

Because the saturation magnetization of Ferrite material is about 0.4T, the designed Magnetic flux density in transformer should be no more then 0.4T. However, Single-ended Flyback circuits works in the first quadrant of B-H, and residual magnetism of the core is about 0.1T, so the maximum working magnetic flux density should be $0.4-0.1=0.3T$.

$$B_{max} = (400 * 2.4) / (192 * 20) = 0.25$$

$B_{max} < 0.3$, so the design is workable.

11.2.9 Leakage inductance of a transformer

It is suggested to use P/S/P way to wind the transformer so that to reduce the leakage inductance.

12. SPECIAL NOTICE FOR PBC LAYOUT DESIGN

12.1 Heat dissipation: A good estimate is that the controller will dissipate the output power. So enough cooper area connected to the 5, 6, 7, 8 COLLECTED pins and tin-plating are necessary to provide the controller heat sink.

12.2 The 5, 6, 7, 8 COLLECTED pins is high voltage part of the IC, peak voltage is as high as 600V, so it should be at least 1.5mm far away from the low voltage part in the PCB as to avoid circuit breakdown and discharging.

12.3 Pin No.1 is for testing only. It is prohibited to be connected with other circuits when in use.

13. MECHANICAL AND PACKING INFORMATION

Symbol	Dimensions In Millimeters		Dimensions In Inches	
	Min	Max	Min	Max
A	3.710	4.310	0.146	0.170
A1	0.510		0.020	
A2	3.200	3.600	0.126	0.142
B	0.380	0.570	0.015	0.022
B1	1.524 (BSC)		0.060 (BSC)	
C	0.204	0.360	0.008	0.014
D	9.000	9.400	0.354	0.370
E	6.200	6.600	0.244	0.260
E1	7.320	7.920	0.288	0.312
e	2.540 (BSC)		0.100 (BSC)	
L	3.000	3.600	0.118	0.142
E2	8.400	9.000	0.331	0.354

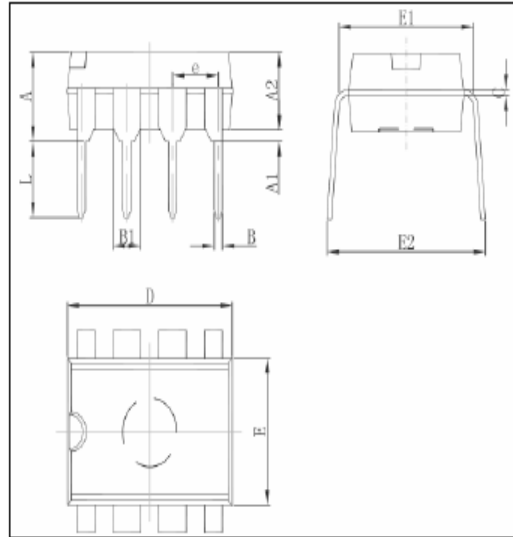

· **Anti-static tube packing**

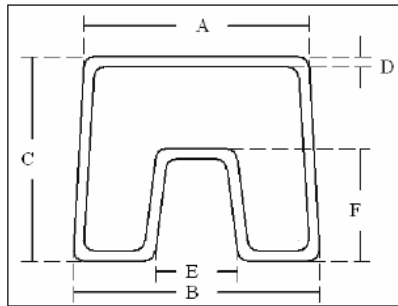

CODE	Min.(mm)	Typ.(mm)	Max.(mm)
A	11	11.5	12
B	11.5	12	12.5
C	10	10.5	11
D	0.4	0.5	0.6
E	3.5	4	4.5
F	5	5.5	6

· **Packing quantity**

QTY/tube	QTY/inner carton	QTY/master carton
50	2000	20000